

PRONOVA 525H & 535H



Pronovas 525H and the stainless steel model 535H are robust and highly efficient packaging machines for horizontal bag packaging.

Designed for 24-hour-use in automated packaging lines where the products need to be packed horizontally. A supporting conveyor belt keeps the bags horizontally through the sealing unit. The stainless steel model is especially well suited for products that require hygienic packing as it can be thoroughly rinsed and cleansed.

Filling options

The machine is integrated with a filler that horizontally feeds the set amount of product that it fills the bags with, either one or two bags at a time.

With a continuous product flow from a production unit. Pronova can supply for a product counter and equipment that collects the product while pulling a new bag in position.

For oriented products, bags can be perfectly opened to fit the shape of the product and then firmly held in position to create a tight package.

PLC system

The machine is equipped with a PLC system. The operator panel gives all necessary machine information and its touch-button display with universal symbols is highly operator-friendly.

Flexibility

- Versatile design - easily adjusted to fit products and productions.
- Opening arms can be up to 5 meters long.
- Bag width - 50 - 800 mm.
- Bag features - reclosability, perforation, hanger holes, reinforced headers etc.
- Materials - PE, PP, laminates.
- Continuous or intermittent bag feed.

Standard

- Preset counter for automatic stop after preset number of bags
- Automatic intermittent bag feeding with adjustable stop position
- Preset counter for number of bags per feed
- Continuous feeding of bags
- Out- and inputs for communicating with automated lines
- Speed control for bag feeding

Options

- Imprinters
- Labellers
- Product counter
- Compression unit
- Modem
- Recipe management



Technical description

525H & 535H

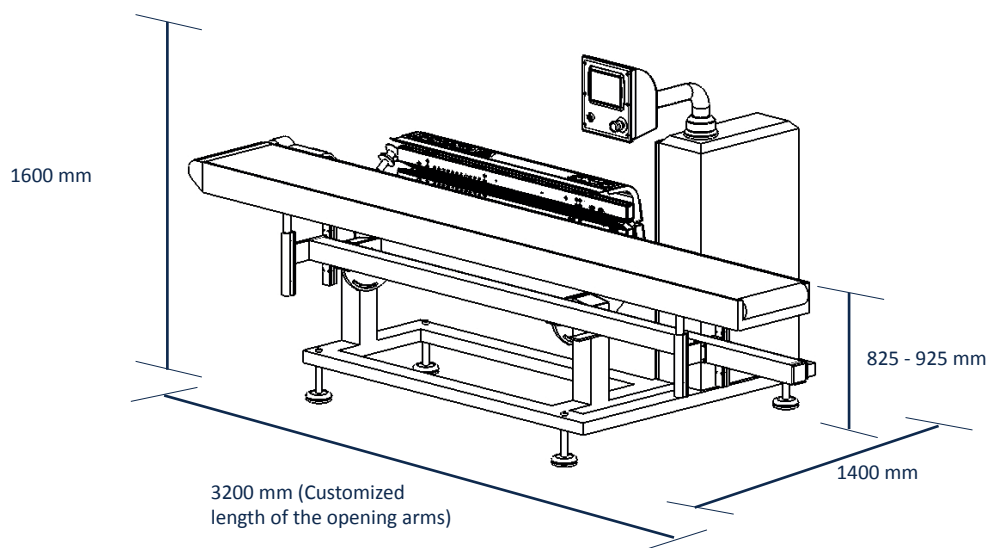

Quality & Safety

The Pronova packaging system stands for quality, safety and accountability.

Every part of the business complies with the standards set by ISO 9001 from the time we begin the design and production of machines and packaging to delivery, service, education and support. Our plastic factory is certified in accordance with ISO 22000

All machines are CE marked.

The Pronova packaging machines are designed with few moving parts and with a simplicity that makes them easy to use and easy to maintain. The welding unit is easy to disassemble without the use of any tools.

Our distributors and licensees around the world all take responsibility for the supply of machinery and materials, and they are all well trained for installation, training and service of our machines.



For further information, don't hesitate to contact us:

Pronova AB
Olofsdalsvägen 26
302 41 Halmstad
Sweden

Tel: +46 (0)35 17 19 00
sales@pronovaab.se
www.pronovaweden.eu

Technical specifications Pronova 525H & 535H

Machine weight:	350 kg
Standard sealing speed:	12 m/min
Power:	2,5 kW
Electrical supply:	400 V 3-fas
Compressed air:	600 kPa, 0,06 m ³ /h

